

function

The SCITEQ copy milling machine is especially developed for the shaping of plastic samples, for tensile tests, and other kinds of elongation tests.

highlights

- simple set-up
- robust construction
- high precision milling
- easy maintenance
- simple to operate

features

Our intention was to produce a machine which can be used with the minimum of skill and training. The result is an **extremely simple to operate unit**. The machine consists of a solid base frame with a 2 axis linear movement milling top. A template is mounted on the machine which provides the profile for the sample. Operator control is via an integrated panel at the front of the machine.



We wish to give our partners the tools to produce to the highest standard, while helping them to produce as cost-effectively as possible with Q.C. tools throughout the factory.

construction

A suitable template should be installed in the machine which provides the profile for the sample, these can be supplied to all dumbbell sample standards.

The sample is secured to the turntable using a support bar located with 2 nuts. The depth of cut can be adjusted and the max. depth of the rough pass milling depth is 4mm. The actual milling depth can be set using the dial gauge.

When getting closer to the desired size, the milling depth should be reduced thus typically only removing 0.1mm each pass which ensures the best surface finish for the sample. This is critical for obtaining correct results from the tensile test itself.

The system can be supplied with a vacuum device which removes the milling swarf into a storage bag. This can be retro-fitted if so desired.

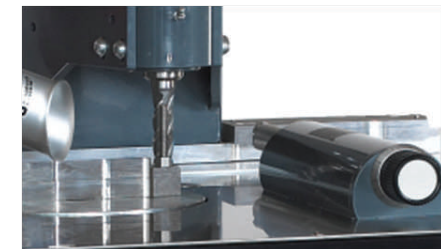

milling mechanism

associated equipment ▲ essential equipment

sample templates

exhaust

milling motor: VEM KPEZ, 80KZ, 2800 rpm.

milling type/cutter: Ø 22 mm 6 cutters, MK3, OSG 8002 DIN 844L, end mill with 53mm cutter, cutter length: standard 75mm, or extra length 125mm.
Others on request.

electrical supply: 3 x 400V + N + PE, 50Hz 10amp

compressed air: 5-7bar

samples: wall thickness up to 60 mm

material to be milled: any plastics or composite material

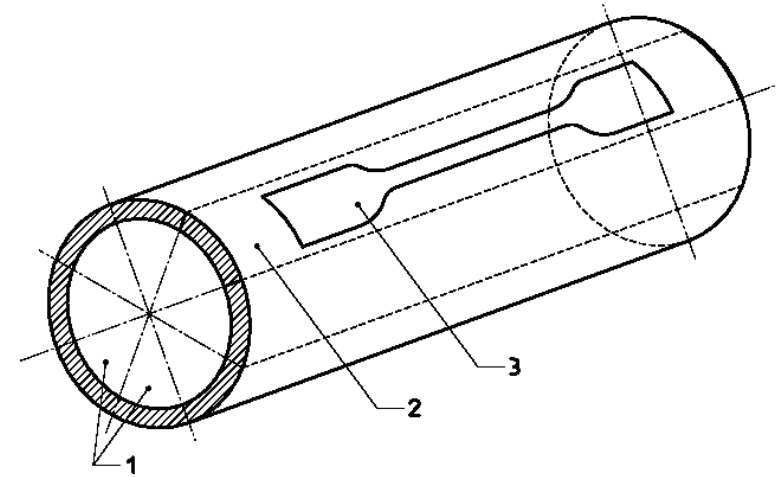

- Key**
- 1 Sectors
 - 2 Strip
 - 3 Test piece

The SCITEQ copy miller can prepare samples according to the international standards such as: ISO 527 and ISO 6259

accessories:

exhaust: external suction device to remove swarf from cutting area

templates: a template is required for each different profile of dumbbell

SCITEQ A/S
 Rho 3
 DK-8382 Hinnerup
 Denmark
 Tel: +45 86 96 19 33
 Fax: +45 86 96 24 75
 www.sciteq.com
 sales(at)sciteq.com

associated | equipment | essential equipment

sample
templates

exhaust